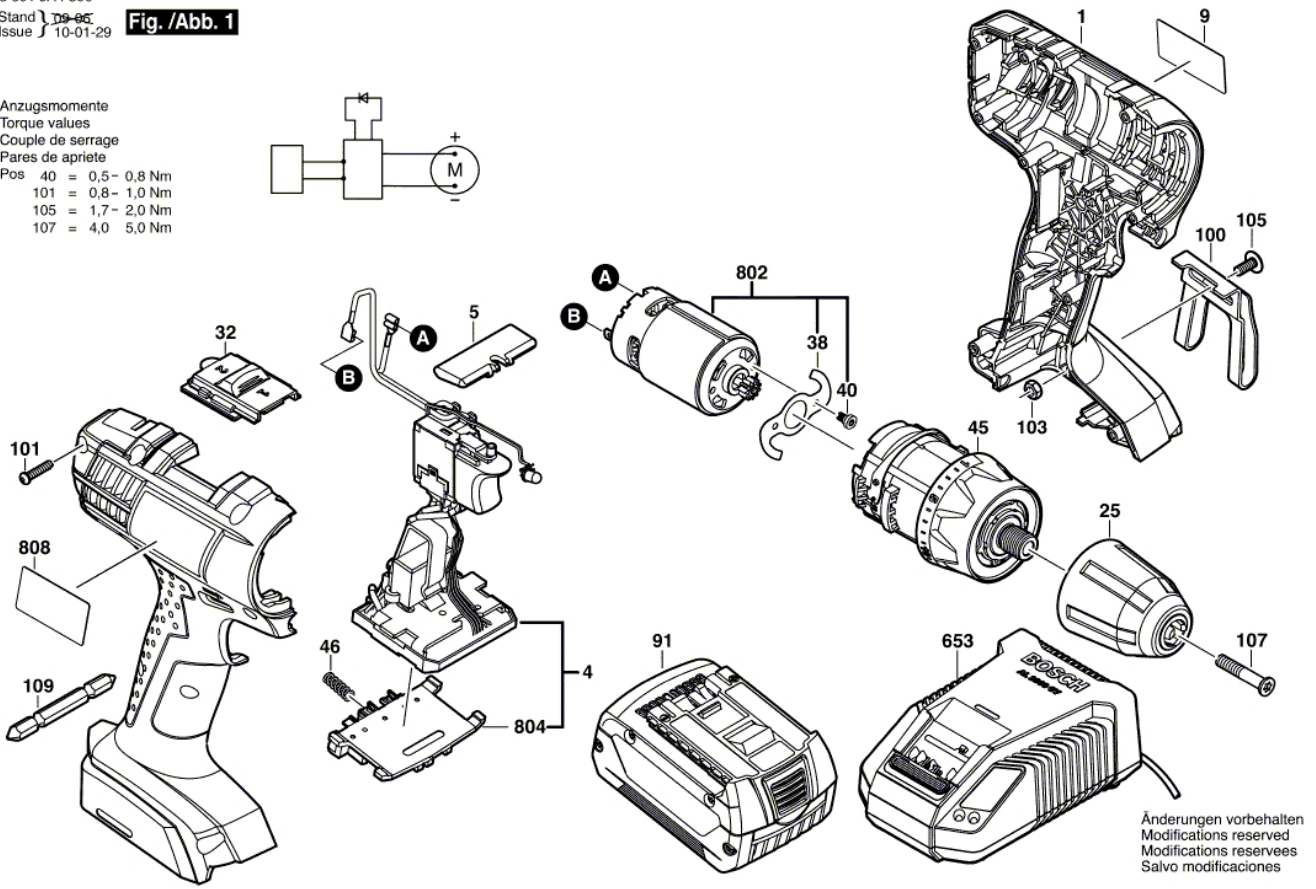
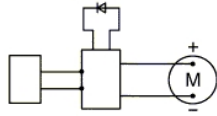

Fig./Abb. 1

Anzugsmomente
 Torque values
 Couple de serrage
 Pares de apriete

Pos	40	=	0,5 - 0,8 Nm
	101	=	0,8 - 1,0 Nm
	105	=	1,7 - 2,0 Nm
	107	=	4,0 - 5,0 Nm



Änderungen vorbehalten
 Modifications reserved
 Modifications reserves
 Salvo modificaciones